



SPECIAL FEATURES

- STAINLESS STEEL CASE & MEASURING SYSTEM
- RUGGED CONSTRUCTION
- DRY OR LIQUID FILLED
- STANDARD FOLLOWED IN GENERAL EN 837-1

APPLICATIONS

FOOD & BEVERAGE, PHARMACEUTICAL, CHEMICAL & PETROCHEMICAL INDUSTRIES, CONVENTIONAL & NUCLEAR POWER PLANTS, PUMPS, HYDRO-CLEANING MACHINES, PRESSES, ENGINE COMPRESSORS, TURBINES, DIESEL ENGINES, HYDRAULIC EQUIPMENTS, REFRIGERATING PLANTS AND GASEOUS / LIQUID MEDIA THAT WILL NOT OBSTRUCT THE PRESSURE SYSTEM.

SPECIFICATIONS

STANDARD VERSION : 40 mm, 50 mm, 63 mm & 80 mm

Accuracy	: ± 1.6% of F. S.(For NS 63 mm & NS 80 mm) & ±2.5% of F. S.(For NS 40 mm & 50 mm)
Ambient temperature	: - 25°C to + 65°C
Process temperature	: Max 180°C
Operating pressure	: 75 % of Scale Value
Over pressure limit	: ≤ 100 bar : 125% of Max. Scale Value : > 100 to ≤ 600 bar : 115% of Max. Scale Value : > 600 to ≤ 1600 bar : 110% of Max. Scale Value

Case & Bezel	: AISI 304 SS (Bayonet type) & Rolling type for NS 40 mm
Socket	: AISI 316 SS
Bourdon	: AISI 316L SS
Movement	: AISI 304 SS
Joints	: Tig Argon Arc Welding

Protection	: IP 65
Dial	: Aluminium, black graduation on white background
Pointer	: Black Coloured, Fixed
Window	: Plexi Glass
Filling Plug	: Neoprene
Gasket	: Neoprene / Silicon rubber

DRY BUT FILLABLE VERSION (OPTION FG)

Fillable Dampening Liquid:	Glycerine 99.7%
Ambient Temperature	: Maximum 65°C
Process Temperature	: Maximum 65°C
Other Features	: Refer Specification of Standard Version

GLYCERINE FILLED VERSION (OPTION PY)

Accuracy	: ±1.6% of F. S.(For NS 63 mm & Ns 80 mm) & ±2.5% of F. S.(For NS 40 mm & 50 mm)
Ambient Temperature	: Maximum 65°C
Process Temperature	: Maximum 65°C
Window	: Plexi Glass
Dampening Liquids	: Glycerine 99.7%
Other Features	: Refer Specification of Standard Version

Temperature effect:

The variation of indication caused by effects of temperature is to be calculated by below formula; which is to be added in the specified accuracy while measurement :- Formula : $\pm 0.04 \times (t_2 - t_1) \% \text{ of F. S.}$:where t_1 = reference temperature (+20°C) and t_2 = ambient temperature in °C.



DIMENSIONS - STANDARD VERSION

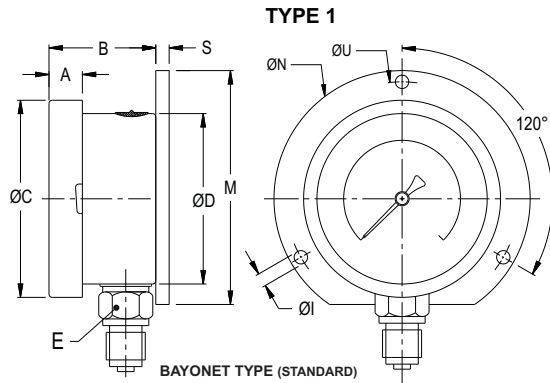

NS	A	B	ØC	ØD	E	S	ØN	ØI	ØU	M	Weight in gram (With Box)	Weight in gram (With Glycerin & Box)
63	10	32	69.5	62.5	A/F 14	7	86	3.6	75	80	215.0	265.0
80	11	35	89.5	80	A/F 14	4	110	5	94	95	300.0	380.0

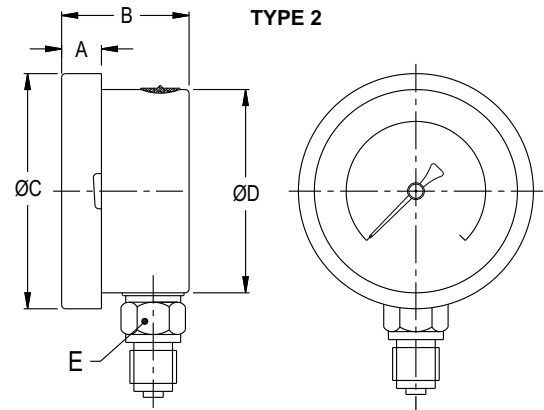

BAYONET TYPE (STANDARD)

NS	A	B	ØC	ØD	E	Weight in gram (With Box)	Weight in gram (With Glycerin & Box)
50	10	32.5	58.5	51	A/F 14	153.0	210.0
63	10	31	69.5	62.5	A/F 14	180.0	240.0
80	11	35	89.5	80	A/F 14	250.0	330.0

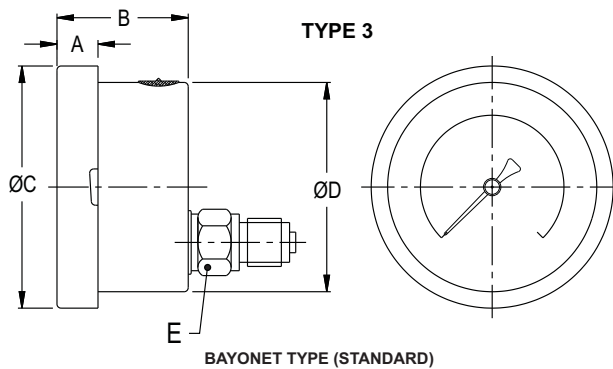

BAYONET TYPE (STANDARD)

NS	A	B	ØC	ØD	E	Weight in gram (With Box)	Weight in gram (With Glycerin & Box)
63	10	32	69.5	62.5	A/F 14	190.0	250.0

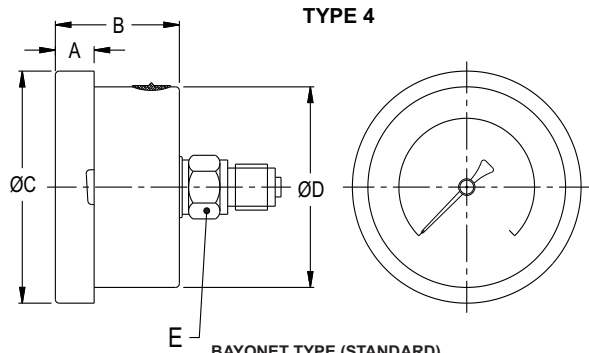

BAYONET TYPE (STANDARD)

NS	A	B	ØC	ØD	E	Weight in gram (With Box)	Weight in gram (With Glycerin & Box)
50	10	32.5	58.5	51	A/F 14	170.0	230.0
63	10	32	69.5	62.5	A/F 14	188.0	250.0
80	11	35	89.5	80	A/F 14	240.0	320.0

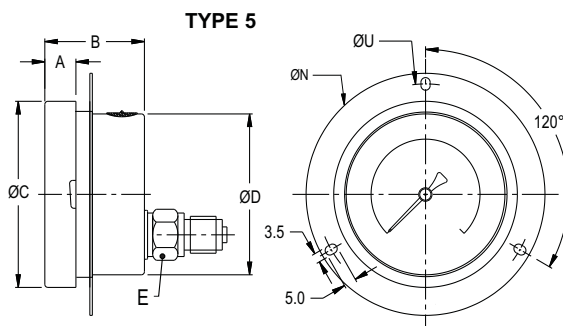

BAYONET TYPE (STANDARD)

NS	A	B	ØC	ØD	E	ØN	ØU	Weight in gram (With Box)	Weight in gram (With Glycerin & Box)
63	10	32	69.5	62.5	A/F 14	86	75	213.0	275.0

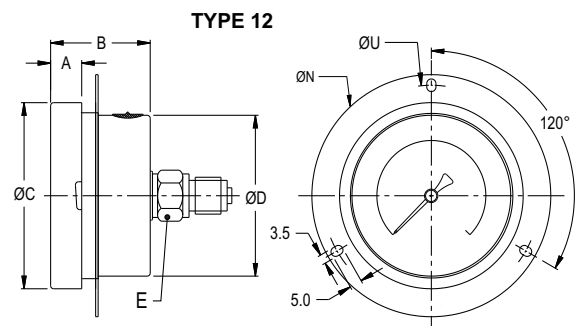

BAYONET TYPE (STANDARD)

NS	A	B	ØC	ØD	E	ØN	ØU	Weight in gram (With Box)	Weight in gram (With Glycerin & Box)
63	10	32	69.5	62.5	A/F 14	86	75	213.0	275.0

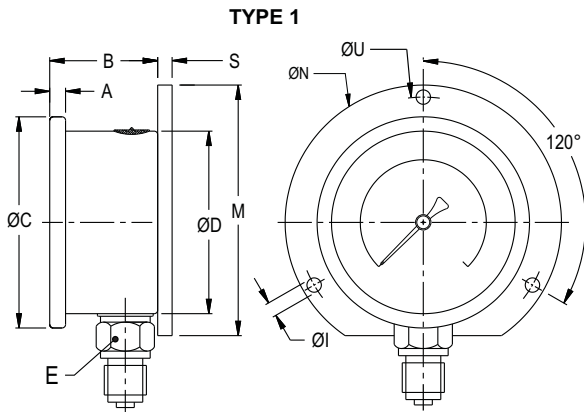

TYPE 1

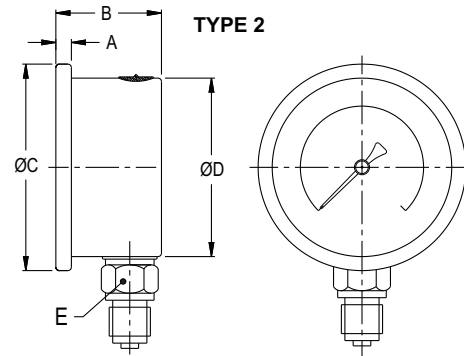

TYPE 2

ROLLING TYPE (OPTION SQ)

NS	A	B	ØC	ØD	E	S	ØN	ØI	ØU	M	Weight in gram (With Box)	Weight in gram (With Glycerin & Box)
40*	5	29	45.5	41	A/F 14						90.0	130.0
50	5	29	57.5	51.5	A/F 14						125.0	185.0
63	6.5	30.5	69	62.5	A/F 14	7	86	3.6	75	80	190.0	250.0

ROLLING TYPE (OPTION SQ)

NS	A	B	ØC	ØD	E	Weight in gram (With Box)	Weight in gram (With Glycerin & Box)
40*	5	29	45.5	41	A/F 14	90.0	130.0
50	5	29	57.5	51.5	A/F 14	125.0	185.0
63	6.5	30.5	69	62.5	A/F 14	140.0	200.0

* ROLLING TYPE (STANDARD)

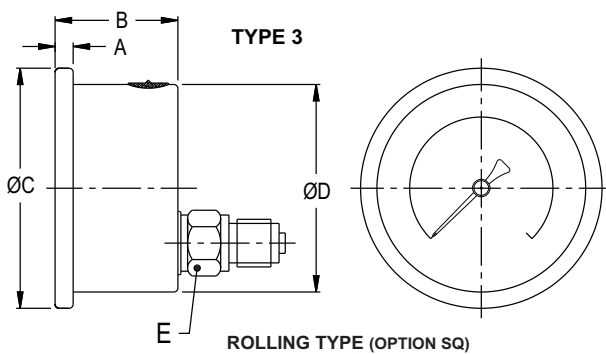

TYPE 3

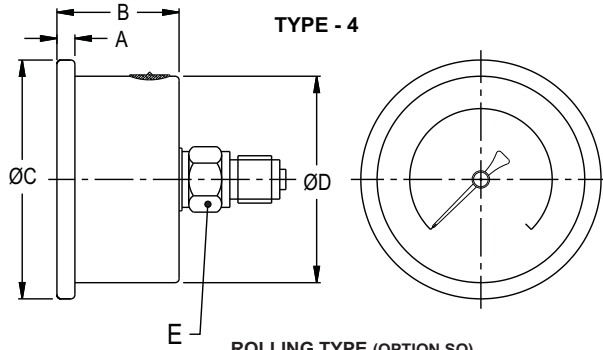

TYPE - 4

ROLLING TYPE (OPTION SQ)

NS	A	B	ØC	ØD	E	Weight in gram (With Box)	Weight in gram (With Glycerin & Box)
63	6.5	30.5	69	62.5	A/F 14	160.0	220.0

ROLLING TYPE (OPTION SQ)

NS	A	B	ØC	ØD	E	Weight in gram (With Box)	Weight in gram (With Glycerin & Box)
40*	5	29	45.5	41	A/F 14	100.0	140.0
50	4.5	29	57.5	51.5	A/F 14	117.0	167.0
63	6.5	30.5	69	62.5	A/F 14	170.0	230.0

* ROLLING TYPE (STANDARD)

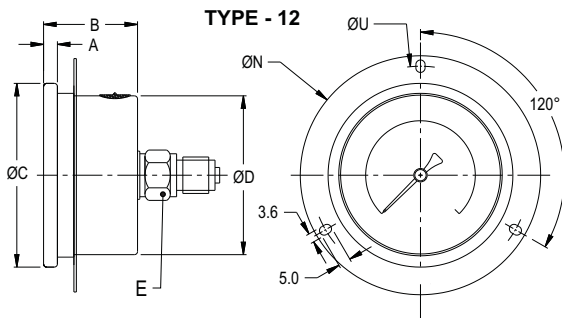

TYPE - 12

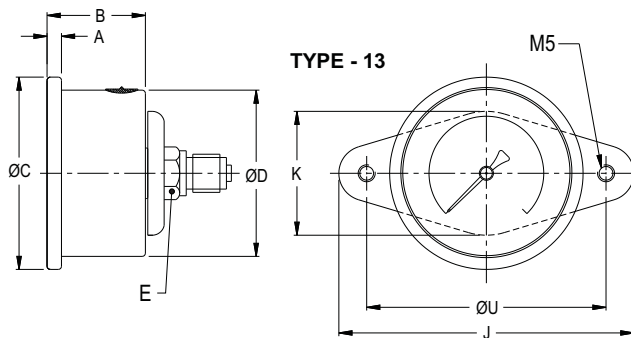

TYPE - 13

ROLLING TYPE (OPTION SQ)

NS	A	B	ØC	ØD	E	ØN	ØU	Weight in gram (With Box)	Weight in gram (With Glycerin & Box)
63	6.5	30.5	69	62.5	A/F 14	86	75	220.0	280.0

ROLLING TYPE (STANDARD)

NS	A	B	ØC	ØD	E	J	K	ØU	Weight in gram (With Box)	Weight in gram (With Glycerin & Box)
50	5	29	57	51.5	A/F 14	91	38	70.5	180.0	240.0
63	6.5	30.5	69	62.5	A/F 14	91	38	70.5	210.0	270.0

Notes : • Drawings are not to scale. • All Dimensions are in mm .• NS = Nominal Seize
 • Weights mentioned are approximate and for standard product. Weight can be different after selection of options.

RANGE TABLE

Note : Waaree offers Pressure ranges, Vacuum ranges and Compound ranges in Scales like kPa, MPa, bar, psi, kg/cm² & Dual Scale like kPa with psi, kPa with bar, bar with psi or scales as per the requirement can be provided on request. Following are the example tables for kg/cm² & psi scales

RANGE WITH NOMINAL SIZES

NOMINAL SIZE		40 mm	50 mm	63 mm	80 mm
RANGE (psi with kg/cm ²)					
psi	kg/cm ²				
-30 inHg / 0	-760 mmHg / 0	✓	✓	✓	✓
0/15 psi	0/1 kg/cm ²	✓	✓	✓	✓
0/30psi	0/2 kg/cm ²	✓	✓	✓	✓
0/60 psi	0/4 kg/cm ²	✓	✓	✓	✓
0/100 psi	0/7 kg/cm ²	✓	✓	✓	✓
0/150 psi	0/10 kg/cm ²	✓	✓	✓	✓
0/220 psi	0/16 kg/cm ²	✓	✓	✓	✓
0/300 psi	0/20 kg/cm ²	✓	✓	✓	✓
0/400 psi	0/28 kg/cm ²	✓	✓	✓	✓
0/500 psi	0/35 kg/cm ²	✓	✓	✓	✓
0/600 psi	0/42 kg/cm ²	✓	✓	✓	✓
0/1000 psi	0/70 kg/cm ²	×	✓	✓	✓
0/1500 psi	0/100 kg/cm ²	×	✓	✓	✓
0/2200 psi	0/160 kg/cm ²	×	✓	✓	✓
0/3000 psi	0/200 kg/cm ²	×	✓	✓	✓
0/4000 psi	0/280 kg/cm ²	×	✓	✓	✓
0/5000 psi	0/350 kg/cm ²	×	✓	✓	✓
0/6000 psi	0/400 kg/cm ²	×	✓	✓	✓
0/10000 psi	0/700 kg/cm ²	×	×	✓	✓
0/15000 psi	0/1000 kg/cm ²	×	×	✓	✓
- 30inHg /30	- 1/2 kg/cm ²	×	×	✓	✓
- 30inHg /60	- 1/4 kg/cm ²	×	×	✓	✓
- 30inHg /100	- 1/7 kg/cm ²	×	×	✓	✓
- 30inHg /150	- 1/10 kg/cm ²	×	×	✓	✓
- 30inHg /200	- 1/14 kg/cm ²	×	×	✓	✓
- 30inHg /300	- 1/21 kg/cm ²	×	×	✓	✓

AMMONIA WITH TEMPERATURE SCALE

- 30° Hg / 150 psi	×	×	✓	✓
- 30° Hg / 300 psi	×	×	✓	✓
0/300 psi	×	×	✓	✓
-1/12.5 kg/cm ²	×	×	✓	✓
-1/16 kg/cm ²	×	×	✓	✓
-1/25 kg/cm ²	×	×	✓	✓

ACCESSORIES (Refer Datasheet for complete specifications)

EC	GAUGE COCK	EG	SNUBBER
ED	OVERLOAD PROTECTOR (GAUGE SAVER)**	EH	SIPHON
*	NEEDLE VALVE	EB	COOLING TOWER

* Refer catalogue for Valves & Manifolds

** For Pressure Ranges.

HOW TO ORDER

Example

BASIC MODEL

CODE

NOMINAL SIZE

B	C	D	E
40 mm	50 mm	63 mm	80 mm

TYPE OF MOUNTING

	B	C	D	E
1 WALL/ SURFACE/ PROJECTION MOUNTING WITH BOTTOM ENTRY	X	X	✓	✓
2 DIRECT BOTTOM ENTRY	✓	✓	✓	✓
3 DIRECT LOWER BACK ENTRY	X	X	✓	X
4 DIRECT CENTER BACK ENTRY	✓	✓	✓	✓
5 LOWER BACK ENTRY WITH FRONT FLANGE	X	X	✓	X
12 CENTER BACK ENTRY WITH FRONT FLANGE	X	X	✓	X
13 CENTER BACK ENTRY WITH MOUNTING BRACKET*	X	✓	✓	X

Note : *Applicable for Rolling type design only.

GAUGE CONNECTION

	B	C	D	E
1BM 1/8" BSP(M)	✓	✓	✓	X
1NM 1/8" NPT(M)	✓	✓	✓	X
1TM 1/8" BSPT(M)	✓	✓	✓	X
2BM 1/4" BSP(M)	X	✓	✓	X
2NM 1/4" NPT(M)	X	✓	✓	X
2TM 1/4" BSPT(M)	X	✓	✓	X
3BM 3/8" BSP(M)	X	X*	X*	✓
3NM 3/8" NPT(M)	X	X*	X*	✓
3TM 3/8" BSPT(M)	X	X*	X*	✓
4BM 1/2" BSP(M)	X	X*	X*	X*
4NM 1/2" NPT(M)	X	X*	X*	X*
4TM 1/2" BSPT(M)	X	X	X*	X*

* These connections will be provided on request. Consult factory for minimum order quantity, price & delivery.

Note : Connections like Metric/ PT/ PF/ Flaired/ UNF/ G/ R etc. can be provided on request.

RANGE

REFER RANGE TABLE

OPTIONAL EXTRAS

RH CUSTOM DESIGNED DIAL	SX SS TAG PLATE
SG OXYGEN SERVICE (FOR DRY VERSION)	TB HELIUM LEAK TEST
PS AISI 316 SS CASE & BEZEL*#	QB INTEGRAL DAMPENING SCREW (AISI 316 SS)
SQ CASE WITH ROLLING TYPE BEZEL**	SJ MAXIMUM READING POINTER WITH PLEXI GLASS (FOR DRY VERSION)*
PW FIVE POINT CALIBRATION CERTIFICATE	RX SHATTERPROOF / SAFETY GLASS (FOR BAYONET TYPE DESIGN)*#
FG FILLABLE LIQUID GLYCERINE	RZ TOUGHENED GLASS (FOR BAYONET TYPE DESIGN)*#
FS FILLABLE LIQUID SILICON OIL***	RR ENCLOSURE PROTECTION IP 66
PY DAMPENING LIQUID GLYCERINE FILLED	RE ENCLOSURE PROTECTION IP 67
QA DAMPENING LIQUID SILICON OIL FILLED***	PU CALIBRATION CERTIFICATE TRACEABLE TO NATIONAL/ INTERNATIONAL STANDARDS
RI 25 MM BOD (EXCEPT MOUNTING 4, 12 & 13)*	SF MOVEMENT WITH DAMPENING JELLY*#
GH MATERIAL TEST CERTIFICATES****	OB ACCURACY ± 1.0% of F. S.*#
SZ WELDED SOCKET TO THE CASE	ZD Ammonia Range (WITH TEMPERATURE SCALE)

* Applicable for NS 63 mm .

Applicable for NS 80 mm .

** Applicable for NS 40 mm, 50 mm & 63 mm.

*** GASKET & FILLING PLUG OF NBR. REFER PRICE LIST FOR VITON.

****MATERIAL TEST CERTIFICATES WILL BE PROVIDED FOR WETTED PARTS ONLY WITH CHEMICAL COMPOSITION TESTING. FOR OTHERS, PLEASE CONSULT FACTORY.

Ordering Example: AD - X - X OR XX - XXX - 0/10 kg/cm² - XX

FOR OTHER OPTIONAL ITEMS, PLEASE CONTACT FACTORY FOR DELIVERY AND MINIMUM QUANTITY OF ORDER.

Note : Specifications and dimensions given in this product catalogue represents the state of engineering at the time of printing.

Modifications may take place and materials specified may be replaced by others without prior notice.